

CUTTING



MOUNTING



POLISHING



HARDNESS TESTING



FLEXICUT

PRECISION MICRO CUTTING MACHINE BY PRESI



For cross sectional analysis of printed circuit boards Flexicut is the ideal flexible machine.
1 machine, 3 sectioning modes.



A STRONG WORLDWIDE PRESENCE THROUGH SUBSIDIARIES AND MORE THAN 35 DISTRIBUTORS

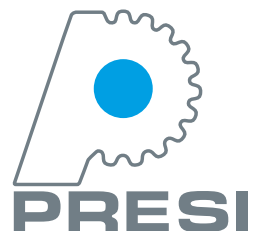

FUNCTIONALITIES

REF. 51800

Width
555mm + 210mm

Depth
665mm

Height closed lid
375mm

Height opened lid
700mm

Weight
52 kg

Conformity
EC

A machine designed for sectioning circuit boards

PCB (Printed Circuit Boards): the multiplicity of formats, soldering techniques, conductivity systems, are various cases that need dedicated tools. Presi created FLEXICUT, a versatile cutting machine designed for the sectioning requirements in the production quality control of printed circuit boards. With its versatility, it is also suited to a variety of other metallographic cutting applications.



Mode: Metallographic cutting of small samples

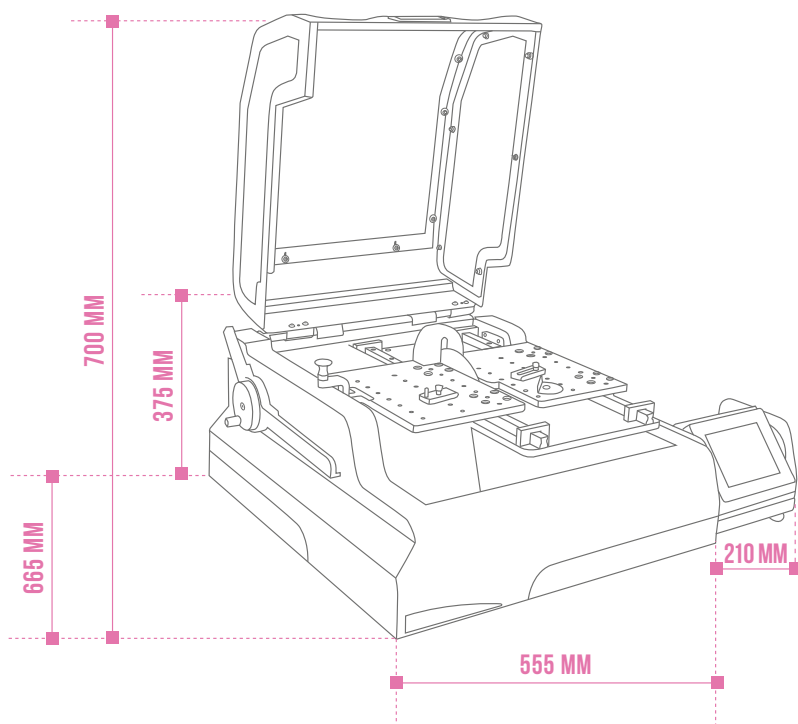

CUTTING ENVELOPE*

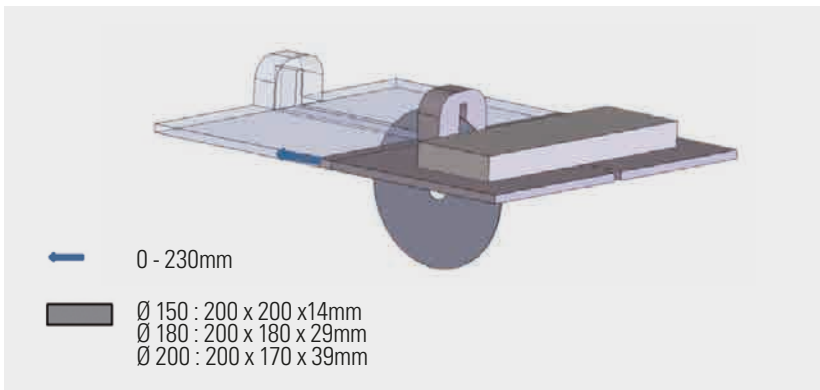

OPTION TABLE
A LONGITUDINALE
MOVEMENT

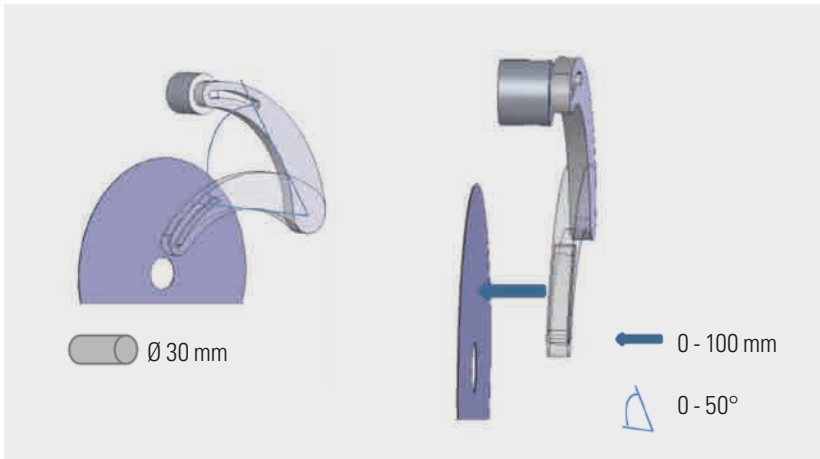

MODE: MICRO CUTTING FLEXICUT

* This illustration of the cutting envelope of the FLEXICUT is to show the maximum theoretical capacity only. The actual capacity in practice will depend on the sample geometry and its physical properties.

FUNCTIONING

INTUITIVE

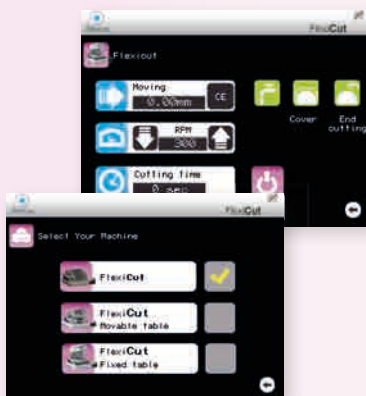

Thanks to the color and multilingual touch screen, Flexicut is programmable for easier use. Centralized commands allow quick access to the main functions of the machine

ERGONOMIC



The Flexicut is intended to be connected with an air extractor.

ROBUST



The Flexicut offers a wide workspace 390 x 200mm. Robust with an ultra-rigid frame and stainless steel table. Maintenance is facilitated by self-cleaning guide rails.

3 CUTTING WAYS

MODE: FORWARD MOVEMENT STAGE FOR PCB CUTS

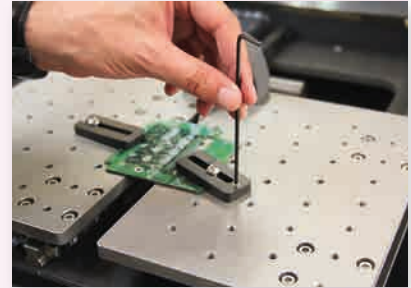
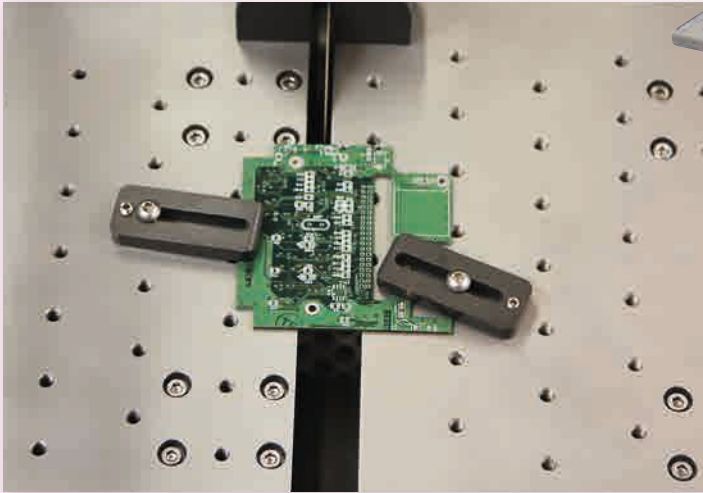

MODE: FIXED STAGE FOR PCB CUTS

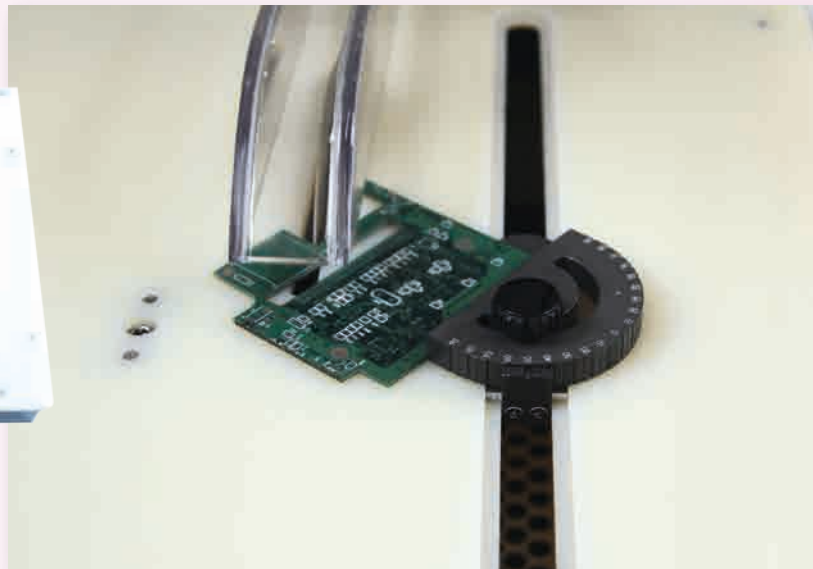
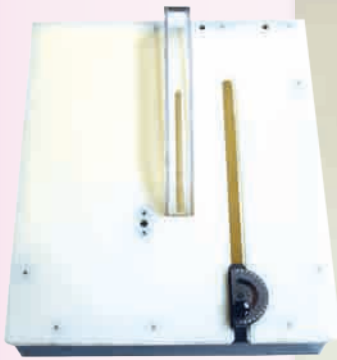

MODE: MICRO CUTTING MACHINE

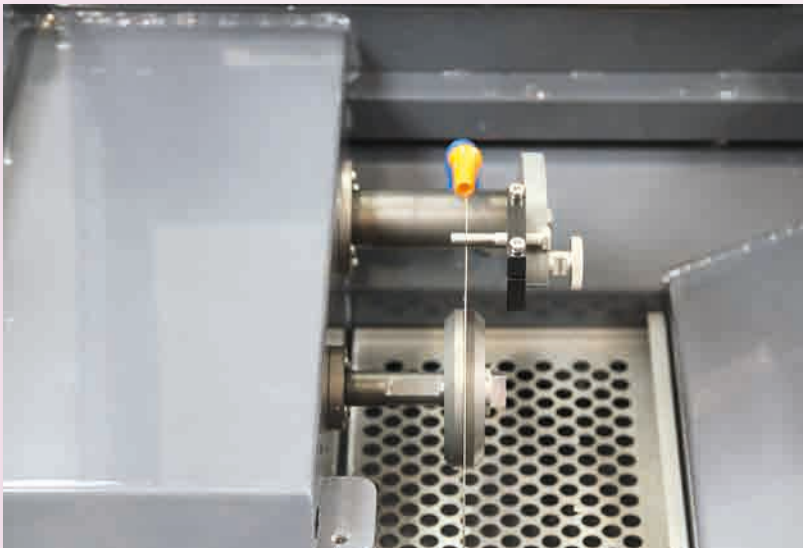

CHARACTERISTICS

HOOD	
Type	PETG enclosure with metal hinges
Safety	Closure switch to cut off motor when hood opened
MOTORIZATION-POWER SUPPLY	
Power	575 W
Power supply	220 V / Single phase / 50 Hz-110 V / Single phase / 60 Hz
CUT-OFF WHEELS	
Type of cut-off wheels	Resin bonded and metal bonded
Cut-off wheel size range	From Ø 75 to Ø 180mm-Ø 200mm for PCB cutting
Rotation speed	From 300 to 2.500 RPM-Option: slow speed kit from 100 to 1.200 RPM
Arbor size	12.7mm
CONTROL	
Control Interface	Color touch control screen
Security Access	Can activate password protection
CUTTING	
Cutting method	Manual or by gravity (Weight/counter-Weight)
Type of table movement	Fixed or moving table options (Y axis) for PCB sectioning
Y axis range	Length of Y axis traverse-230mm
X axis range	100mm X-axis movement of the sample carrier arm
Table dimensions	Fixed table option 390 x 200mm Moving table option 390mm x 200mm (15" x 8")
Table material	Option table with longitudinal movement- micro-rollers stainless steel table
Holders	Sample carrier arm will accept a wide variety of holders
LUBRICATION-COOLING	
Pump & tank	Integrated-Capacity 2.8 L
Type of lubrication	Recirculating pump or drag feed
Method of directing pumped coolant	A single alignable nozzle
Type of filtration	Exchangeable paper filters
ERGONOMICS	
Spray nozzle for cleaning	Integrated
CONFORMITY	
Conformity	EC

ACCESSORIES

Sample chucks

- 51715**
V Shaped sample chuck
- 51717**
Vice chuck for longitudinal cuts
- 51713**
Chuck for small samples (Vice Type)
- 51156**
Orientable chuck (to be used with aluminium plates (Ref. 51162 and 51163)
- 51714**
Chuck for cylindrical sample
- 51716**
Irregular shaped sample chuck
- 51718**
Special tool for angle cut
- 51162-51163**
Set of 5 Aluminium plates 60 x 25mm and 40 x 25mm for samples sticking

Tables and positioning

- 51801**
Forward movement stage for PCB Cuts
- 51802**
Fixed stage for PCB cuts

Flanges

- 51710**
Set of 2 flanges Ø 35 mm for wheel Ø 75 to 100 mm
- 51711**
Set of 2 flanges Ø 50mm for wheel Ø 100 to 150 mm
- 51712**
Set of 2 flanges Ø 75mm for wheel Ø 150 to 180mm

Other accessories

- 51720**
Low speed kit 100 to 1 200 RPM T180/Flexicut
- 51730**
Self lighting LED on magnetic base



REF. 51715



REF. 51717



REF. 51713



REF. 51156



REF. 51714



REF. 51716



REF. 51718



REF. 51162 - 51163



REF. 51801

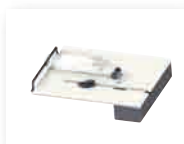

REF. 51802



REF. 51710



REF. 51711



REF. 51712



REF. 51730

CONSUMABLES

STANDARD RESINOID CUT-OFF WHEELS

REF.	DESIGNATION	DIAMETER	HARDNESS	MATERIALS
01040	Type A abrasive Al ₂ O ₃ (ferrous materials)	Ø 100 x 0.3 x 12.7mm	100 - 350 Hv	Low carbon, mild and extra mild and treated steels with medium cross-sections
01046	Type AO abrasive Al ₂ O ₃ (ferrous materials)	Ø 125 x 0.5 x 12.7mm	300 - 500 Hv	Low carbon, mild and extra mild and treated steels with medium cross-sections
01043		Ø 150 x 0.5 x 12.7mm		
01002		Ø 200 x 1.6 x 25.4mm*		
01001	Type AOF II abrasive Al ₂ O ₃ (ferrous materials)	Ø 200 x 0.8 x 25.4mm*	80 - 300 Hv	Rubber bonded cut-off wheel, thin section cutting, low cross-section sintered steels, hard metal layers
01041	Type C abrasive SiC (non ferrous materials)	Ø 100 x 0.3 x 12.7mm	30 - 350 Hv	Aluminium, copper and alloys, non ferrous metals, titanium and alloys
01005	Type MNF abrasive SiC (non ferrous materials)	Ø 200 x 1.6 x 25.4mm*	30 - 350 Hv	Aluminium, copper and alloys, non ferrous metals, titanium and alloys
01060	Type SiC abrasive SiC	Ø 180 x 0.5 x 25.4mm*	450 - 700 Hv	Treated steels, with fragile coatings, difficult materials

* To be used with reduction ring (Ref. 51324)

DIAMOND CUT-OFF WHEELS

REF.	DESIGNATION	DIAMETER	MATERIALS
02030	Type LM	Ø 75 x 0.3 x 12.7mm	Ceramics, composites, tungsten carbide, alumina, sintered carbides
02031		Ø 100 x 0.3 x 12.7mm	
02034		Ø 125 x 0.5 x 12.7mm	
02036		Ø 150 x 0.6 x 12.7mm	
02055		Ø 175 x 0.7 x 12.7mm	
02038		Ø 200 x 0.9 x 32mm*	
02057	Type LM+	Ø 75 x 0.3 x 12.7mm	Ceramics (large sections), tungsten carbide, silicon carbide, plasma deposit, mounted samples, refractory materials, minerals, concretes
02060		Ø 100 x 0.3 x 12.7mm	
02063		Ø 125 x 0.5 x 12.7mm	
02064		Ø 150 x 0.6 x 12.7mm	
02066		Ø 175 x 0.7 x 12.7mm	
02040		Ø 200 x 0.9 x 32mm*	
02058	Type LR	Ø 75 x 0.5 x 12.7mm	Composites, plasma deposit, ceramics, electronic components
02033		Ø 100 x 0.5 x 12.7mm	
02035		Ø 125 x 0.5 x 12.7mm	
02037		Ø 150 x 0.6 x 12.7mm	
02067		Ø 175 x 0.9 x 12.7mm	
02041		Ø 200 x 0.9 x 32mm*	

LM **Metallic bond.** Very polyvalent cut-off wheel, normal concentration, to cut hard materials such as:
■ ceramics, composites, tungsten carbide, alumina, sintered carbides.

LM+ **Metallic bond.** High concentration disc to cut hard materials such as:
■ ceramics (large sections), tungsten carbide, silicon carbide, plasma deposit, mounted samples, refractory materials, minerals, concretes...

LR **Resin bond.** High concentration disc, advised when you want the best cutting quality. To cut hard and fragile materials:
■ composites, plasma deposit, ceramics, electronic components...

BORON CARBIDE CUT-OFF WHEELS

REF.	DESIGNATION	DIAMETER	MATERIALS
02059	Type NB	Ø 75 x 0.5 x 12.7mm	Cast irons, treated steels, hard and high speed steels
02062		Ø 100 x 0.5 x 12.7mm	
02050		Ø 125 x 0.5 x 12.7mm	
02065		Ø 150 x 0.6 x 12.7mm	
02056		Ø 175 x 0.7 x 12.7mm	
02039		Ø 200 x 0.9 x 32mm*	

NB **Resin bond.** High concentration disc of boron nitride edge to cut :
■ Cast irons, treated steels, hard and high speed steels

* To be used with reduction ring (Ref. 51331)



WWW.HOSKIN.CA

- ENVIRONMENTAL
- INSTRUMENTATION
- MATERIALS TESTING
- INTEGRATED SYSTEMS
- RENTALS
- SERVICE

Vancouver | Oakville | Montréal | Edmonton